

Cig-Arrête Standard Controller (Part No CSA-S5B)



Description

At the heart of the Cig-Arrête alarm system, the standard controller performs all the functionality to ensure that your system operates efficiently.

Capable of driving up to 5 Cig-Arrête slave sensors per zone, the controller provides a visual indication of fault and alarm conditions at a remote location. Audible confirmation is facilitated by means of the integral buzzer, which provides a beep at each event.

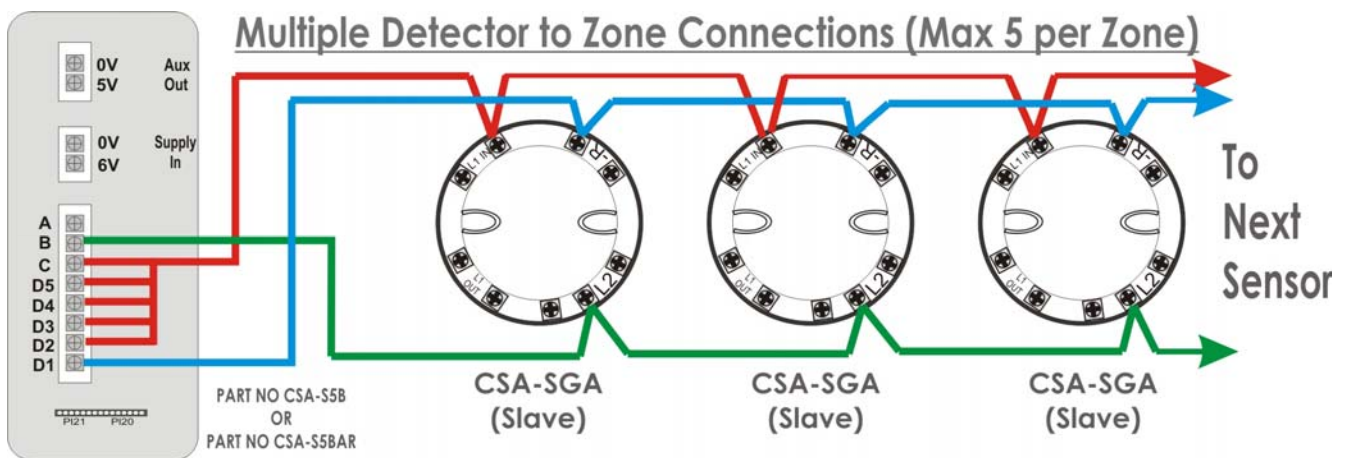

Features

The Controller allows each zone of slave detectors to be monitored from a remote location, without any sound or voice alerts in the protected area.

The Controller may be battery operated by inserting 4 x 'D' type cells into the controller enclosure. Alternatively, an auxiliary power supply (part no CSA-246 or CSA-110) may be used. The slave detectors are connected to each of the five zones as shown above, with a maximum of 5 slave detectors on each zone. The controller has a dual LED for each detector, RED for alarm and YELLOW for fault. Additionally, there is a green LED which pulses to indicate power supply healthy, and a general fault (yellow) LED which indicates system fault or low battery.

All unused zones must be linked to terminal C to ensure that they do not provide a fault under normal conditions.

There are two control buttons provided to SILENCE the alarm condition and RESET the system. Depressing both of these buttons simultaneously generates a lamp test.

The controller is supplied complete with a mounting bracket and full installation instructions